

Model	MX-401		
Mark	AV (AE)	CV (CE)	RV (RE)
1 Front casing	GFRPP		
2 Impeller	GFRPP		
3 Rear casing	GFRPP		
4 Magnet capsule	PP		
5 O-ring	FKM <sup>1</sup>		
6 Spindle	Alumina Ceramic		
7 Bearing	Alumina Ceramic	Carbon	PTFE
8 Rear thrust	CFRPPS		
9 Mouth ring	PTFE		
10 Thrust/Liner ring	Alumina Ceramic		

1 EPDM and AFLAS® O-ring also available.

# MX-401 1.5 HP

- Engineered to meet the most severe operating conditions.
- When fitted with a carbon bearing, the MX will allow for brief periods of dry running.
- The MX Series is the first resin magnet pump that uses a *Split Volute Pump Casing* that forms a vortex chamber.
- Self-radiating structure (patent pending) – Heat dispersion holes force the liquid to circulate around the spindle and bearing .

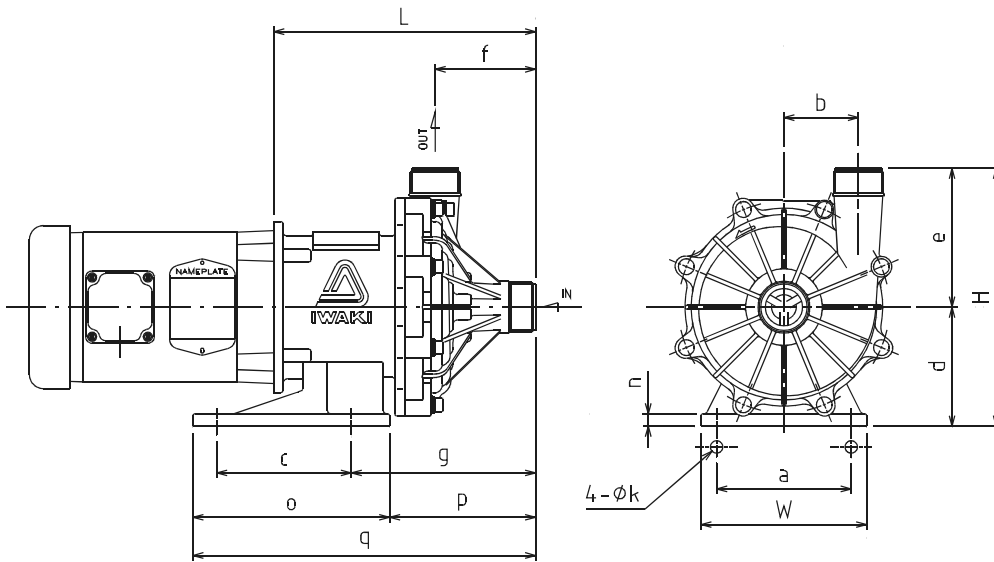

## Dimensions (in inches)

a	b	c	d	e	f	g	k	n	o	p	q	W	H	L
5.12	2.83	5.12	4.53	5.28	3.82	7.01	.47	.47	7.48	5.55	13.03	6.30	9.81	9.96

## Specifications

Suction x Discharge	Maximum Discharge Pressure	Maximum Flow	Specific Gravity	Weight (less motor)
1.5" x 1.5"	6 = 59 ft. 7 = 68 ft.	80 gpm	1.2	22.5 lbs

